



**New Horizon
Lighting**

The Mini-Pack series is a corrosion resistant mini LED based wall pack designed to provide the long life and high reliability required in industrial and commercial applications.

The housing can be mounted directly over a standard 4" box.

Suitable for wet locations, IP66 rated, these lights provide illumination for safety and security along building perimeters.

Features & Benefits

- Uses up to 88% less energy when compared to the HID equivalent
- Instant on/off operation
- Built in Photocell
- Resistant to shock and vibration
- Surge Protection
- Unique optical design provides optimum light distribution
- 4000K color temperature ‡
- Power factor 0.98 (typ)
- Produces no UV radiation
- Contains no Mercury
- 5 year limited warranty

Applications

- Parking areas
- Entrances
- Walkways
- Underpasses
- Loading docks
- Recreation areas

For photometric data and IES files, please contact the factory.

Part Number Listing

Model No.	Light Output	Operating Voltage
NHL-MINI-PACK	1600 lm	90~305 VAC 50/60 Hz

* Other finishes may be available. Contact the factory for details. ‡ Contact factory for details and other options. So that we may continue to supply the best available products, specifications may change. Contact our engineering staff if you require further application information.

**Mini-Pack
Mini 16W
LED Wall Pack**



Product Specifications

Housing:
Durable die cast aluminum with a continuous one piece gasket ensures a weather tight seal.

Lens:
Clear Prismatic Borosilicate glass refractor

LEDs:
Array of 16 x 1 watt Philips Lumileds, providing 1600 lm.

Operating Voltage:
90 ~ 305 VAC 50/60Hz

Finish:
Dark bronze powder paint finish is standard*

Approvals / Ratings:
IP66 rated



UNDERWRITERS LABORATORIES c LISTED

Conforms to UL8750 & EN61347 safety regulations

minipack1011

New Horizon Lighting, 632 Cedar Swamp Road, Jackson NJ
www.newhorizonlighting.com Phone: 732-833-8086 Fax: 732-833-8085



Mini-Pack Mini 16W LED Wall Pack

Dimensions

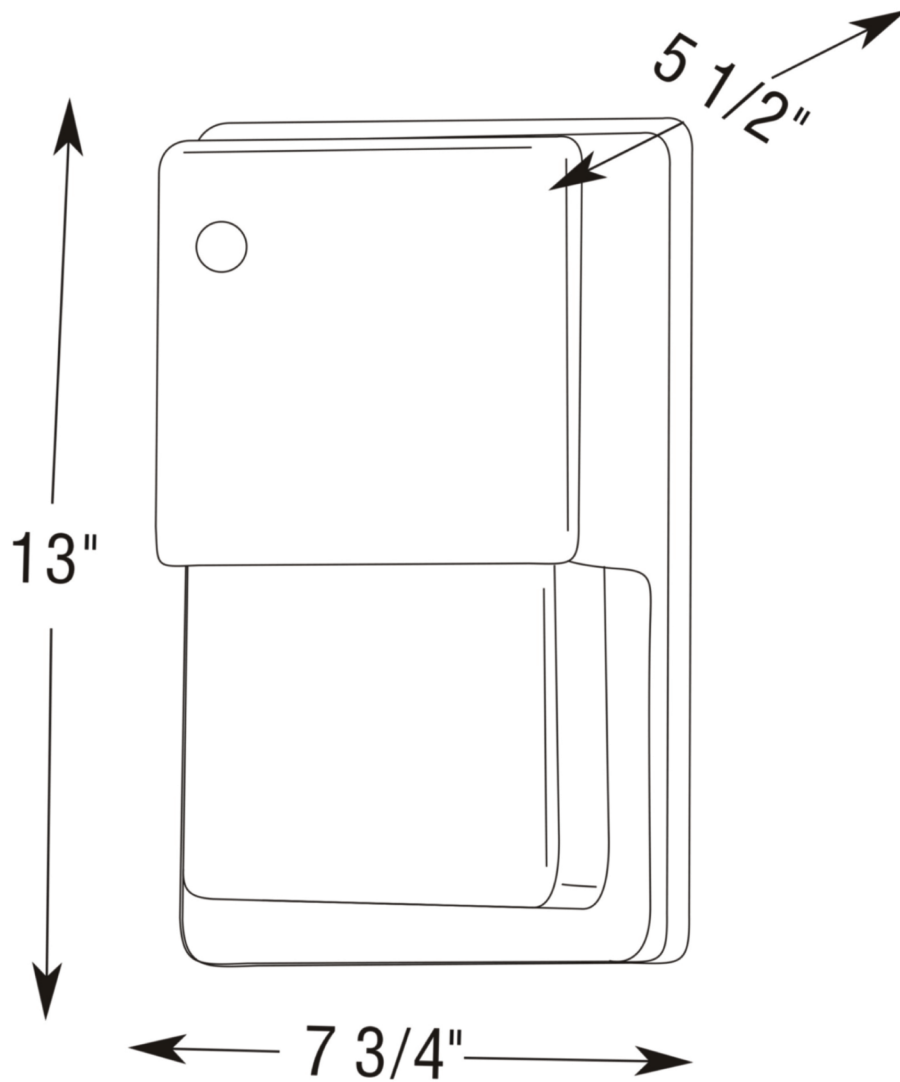

mini-pack1011

New Horizon Lighting, 632 Cedar Swamp Road, Jackson NJ
www.newhorizonlighting.com Phone: 732-833-8086 Fax: 732-833-8085